



KENDRION SOLUTIONS

PM Line

Permanent magnet brake –
High variability in
small installation space

Our brakes – perfect for your safe application

KENDRION Industrial Brakes – stands for smart innovation and excellent service, which we consistently apply for the benefit of our customers:

Strong know-how

Our specialists develop the leading-edge permanent magnet and spring-applied brakes. With INTORQ as a new member of KENDRION, we have once again consistently expanded our range of spring-applied brakes and clutches for you. This way, we can find the right solution for any of your requirements.



Complete product portfolio

Electromagnetic brakes and clutches as well as perfectly matched accessories: with us you will find an exceptionally large selection of quickly available off-the-shelf products that can be put together in a modular system and the best expertise for customer-specific solutions.

Dynamic innovative power

More than 50 specialists working in agile teams in our research and development worldwide are creating convincing product solutions for tomorrow.

Excellent market knowledge

We are very familiar with our focus markets - thanks to extensive experience and research, but also thanks to long-term customer relationships built on partnership and eye-to-eye cooperation.

International power

Committed and competent employees, production sites in Germany, America, India and China as well as a large number of certified sales partners all over the world make us a strong partner for you!

The PM Line

On the point

- Fail-safe permanent magnet brake
- Holding brake with emergency stop function
- In total 10 different sizes available
- Torque range from 0.01 Nm to 240 Nm
- Temperature range from -5°C to +120°C

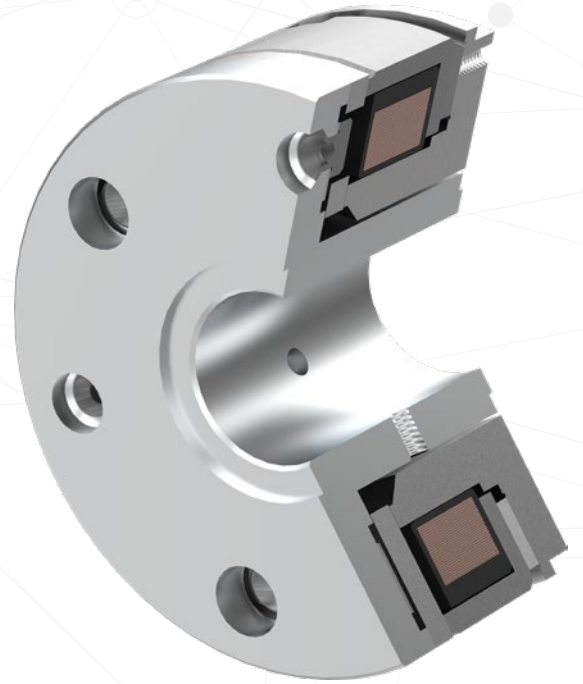

Ideally suited for use in:

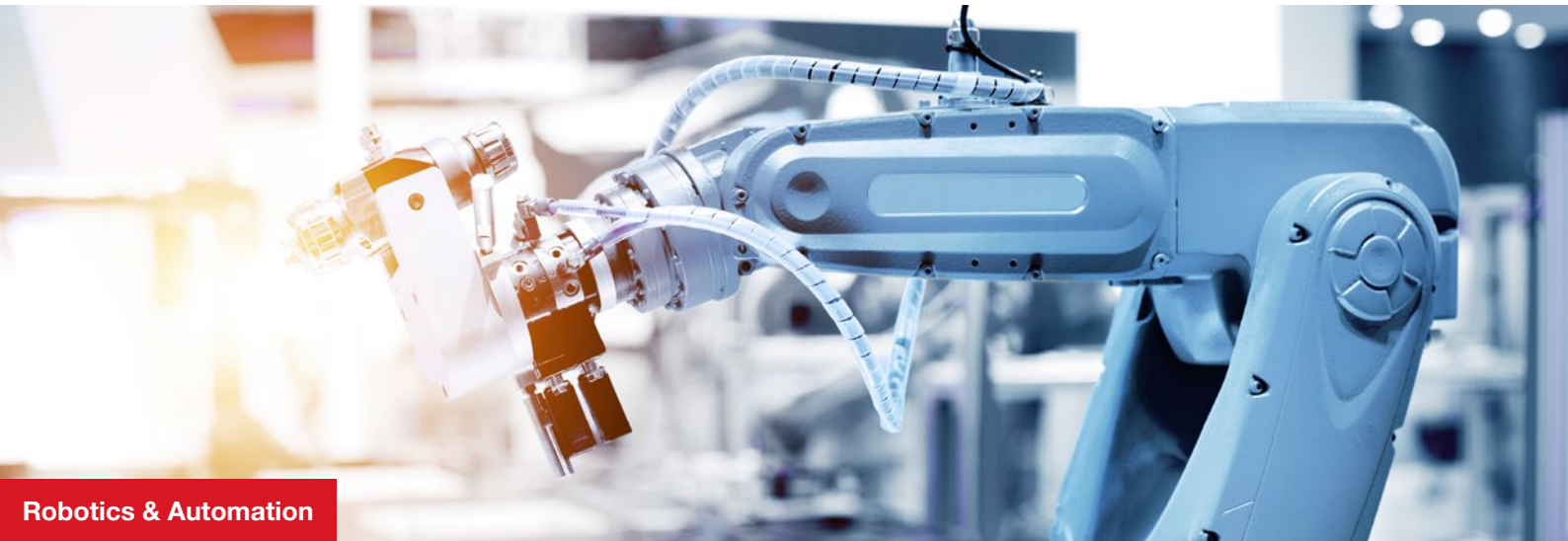

Robotics & Automation



Machine Building



Medical Technology



Massive power needed?

Due to their high power density, wear- and residual torque-free operation and short switching cycles permanent magnet brakes are in most cases the optimum solution in robotics and machine building.

Above all, permanent magnet brakes convince by their compact dimensions and their relatively low weight. Thanks to the high power density of the permanent magnets, the torque achievable with the given installation space is twice as high as usual with spring-applied brakes.

Furthermore, due to their design principle permanent magnet brakes are backlash- and wear-free. Thus, permanent magnet brakes are ideally suited for applications in medical technology and for servomotor applications, e.g. in handling technology and robotics.

Ideal for integration into servomotors

- Designed for integrated installation in the motor
- A- and B-side mounting position on the fixed bearing possible
- Integration in non-motor applications possible e.g. hand-guided tripods

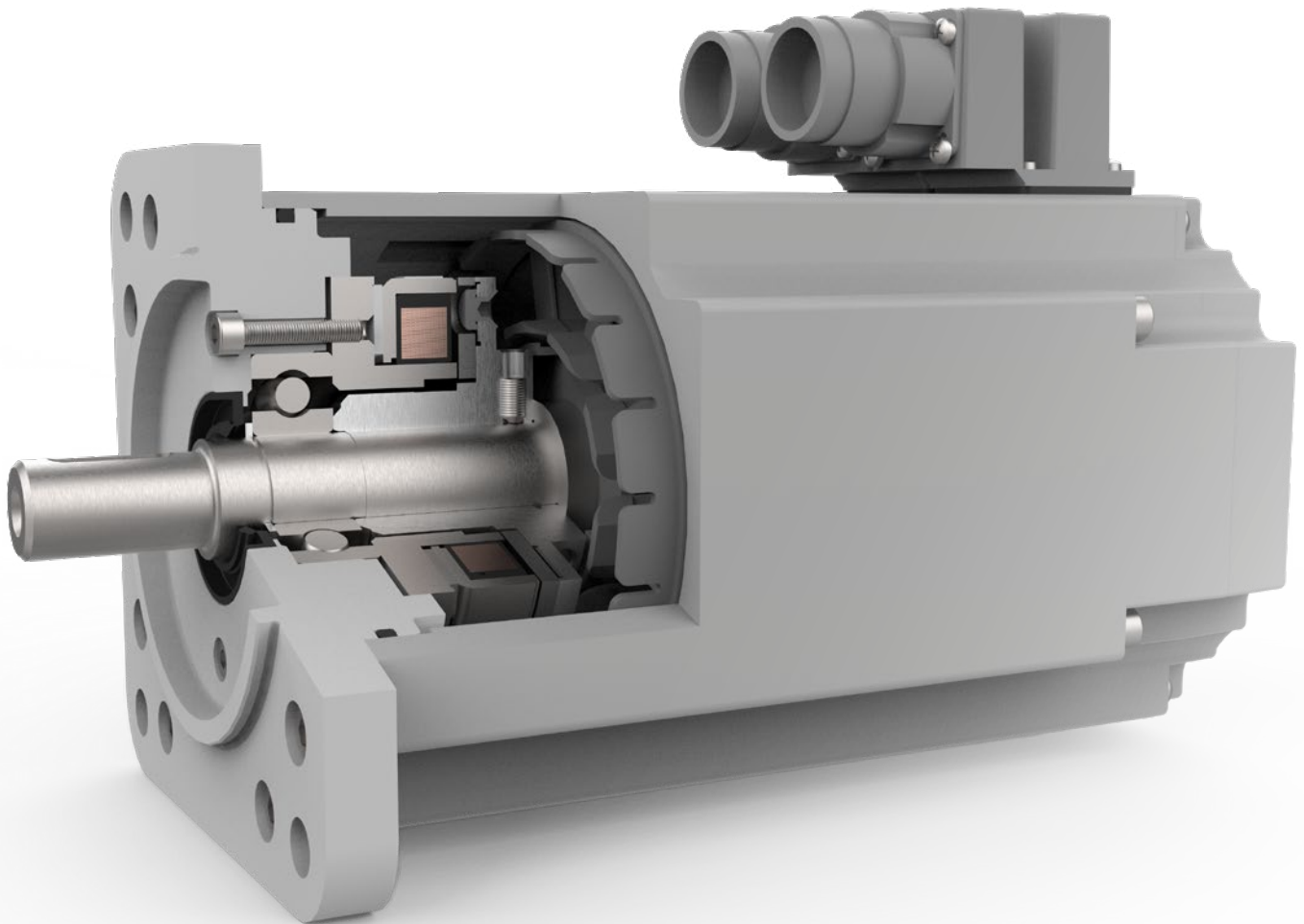

Technical highlights

- High variability due to modular design
- Extended lifetime up to 2,000 emergency stops
- Torque transmission without backlash
- Residual torque-free opening regardless of mounting position
- Wear-free with dynamic changes of direction
- Brakes factory-sided grinded and torque tested

Brake types

The PM Line was especially designed for integration into servomotors and offers different options for the brake configuration. Depending on the size, it is possible to combine the stator system with different coil and armature systems. Please see the table on page 8 for different combination options. We will be pleased to discuss your individual requirements and develop your specific solution.

Stator types

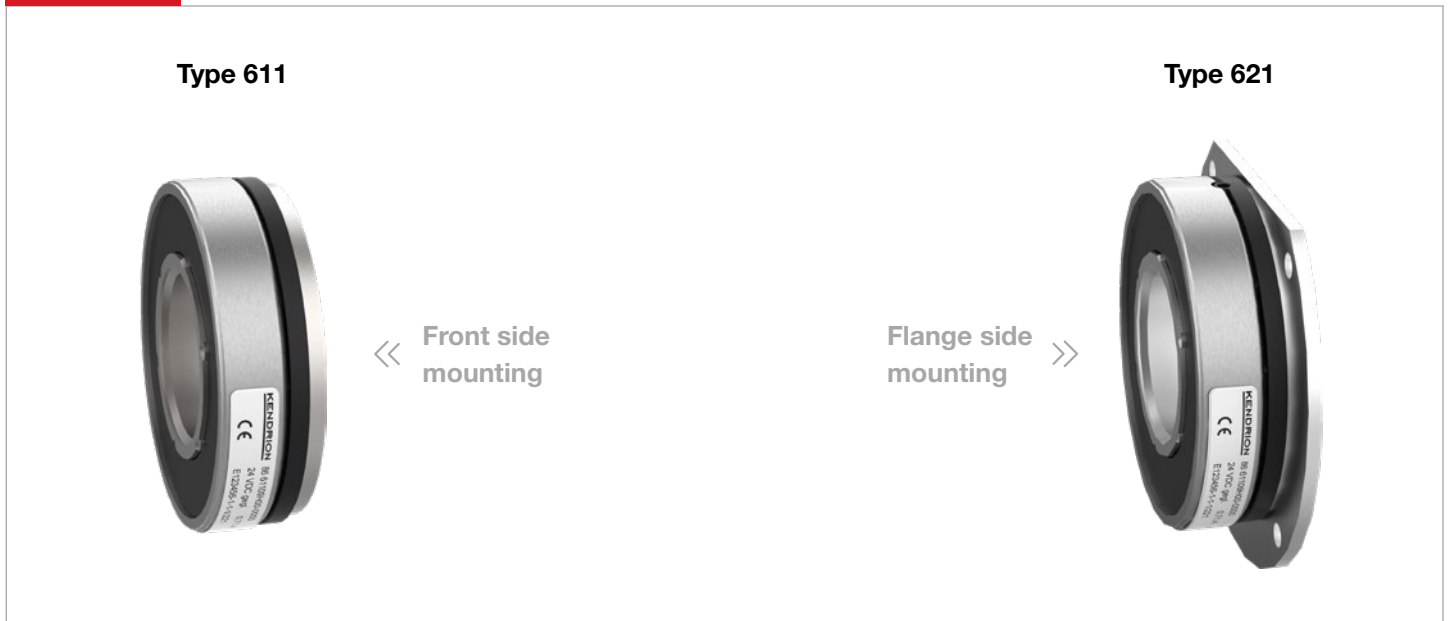

Armature types

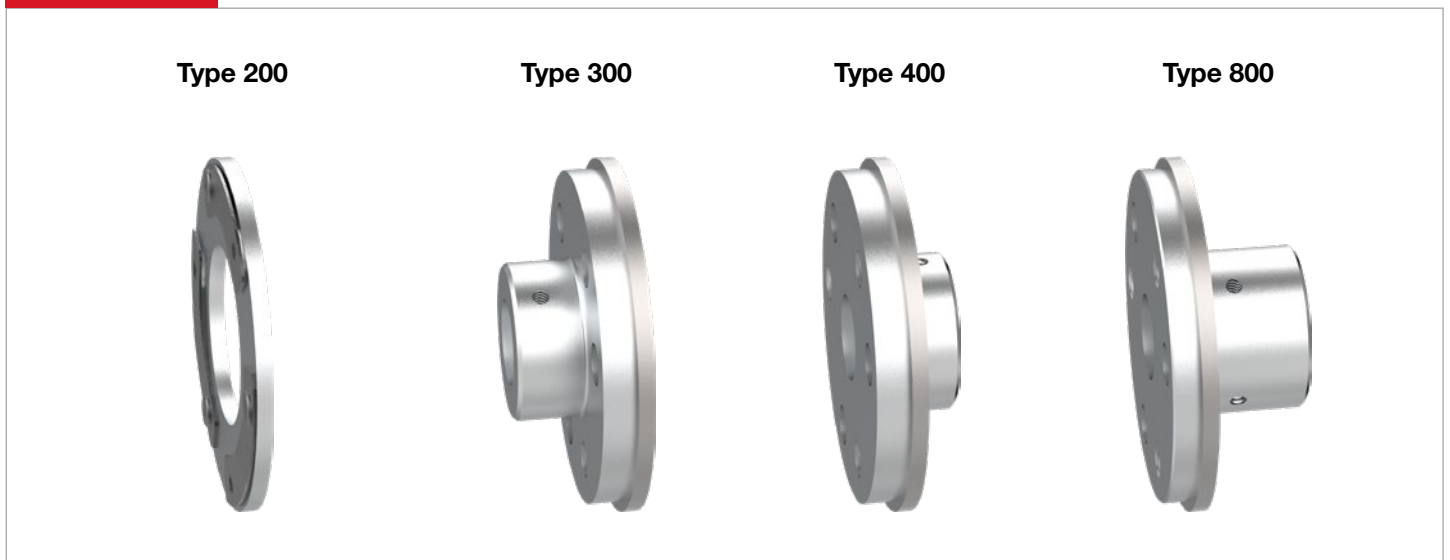

Armature types

We have compiled a selection of our different armature systems for you.
The armature systems depend on the brake type and size.

Armature type 200 Without hub

- Hub in responsibility of customer
- Armature-hub interface acc. specifications
- Air gap adjustment by customer

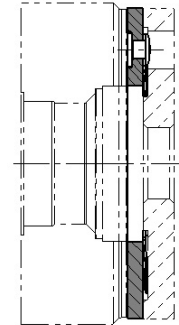

Armature type 300 Manual air gap adjustment

- Short hub
- Fixing thread **outside** brake
- Air gap adjustment by feeler gauge

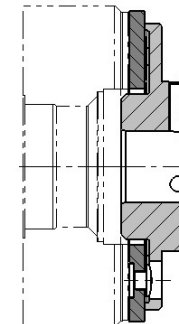

Armature type 400 Manual air gap adjustment

- Short hub
- Fixing thread **inside** brake
- Air gap adjustment by component position

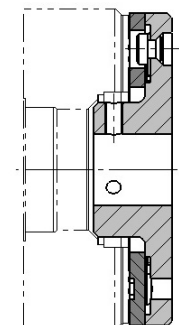

Armature type 800 Automatic air gap adjustment

- Long hub with ball bearing contact
- Fixing thread **inside** brake
- Automatic air gap adjustment by ball bearing

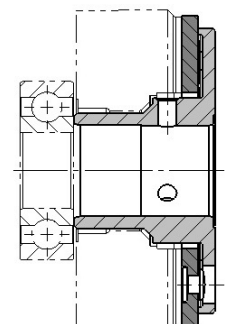

Modular system

Integrated brake systems as used in servomotors usually require customized solutions. The PM Line with its modular system – consisting of stator, armature and coil system – offers the necessary flexibility. Our goal is to configure a customised brake quickly and efficiently with a minimum of development effort to adapted the customer's requirements. Furthermore, we also offer solutions outside of the modular system in coordination with our customers.

Brake size	Stator types		Armature types				Coil types ¹⁾			Brakes grinded and torque-tested at Kendrion
	Type 611 front side mounting	Type 621 flange side mounting	Type 200	Type 300	Type 400	Type 800	12 [VDC]	24 [VDC]	205 [VDC]	
01	■	-	■	-	■	-	-	■	-	-
03	■	■	■	■	-	-	■	■	-	-
04	■	■	■	■	■	-	■	■	-	■
06	■	■	■	■	■	■	■	■	-	■
07	■	■	■	■	■	■	-	■	■	■
09	■	■	■	■	■	■	-	■	■	■
11	■	■	■	■	■	■	-	■	■	■
14	■	■	■	■	■	■	-	■	■	■
16	■	■	■	■	■	■	-	■	■	■
21	■	■	■	-	-	-	-	■	-	■

■ Available as standard

¹⁾ Other voltage variants available on request

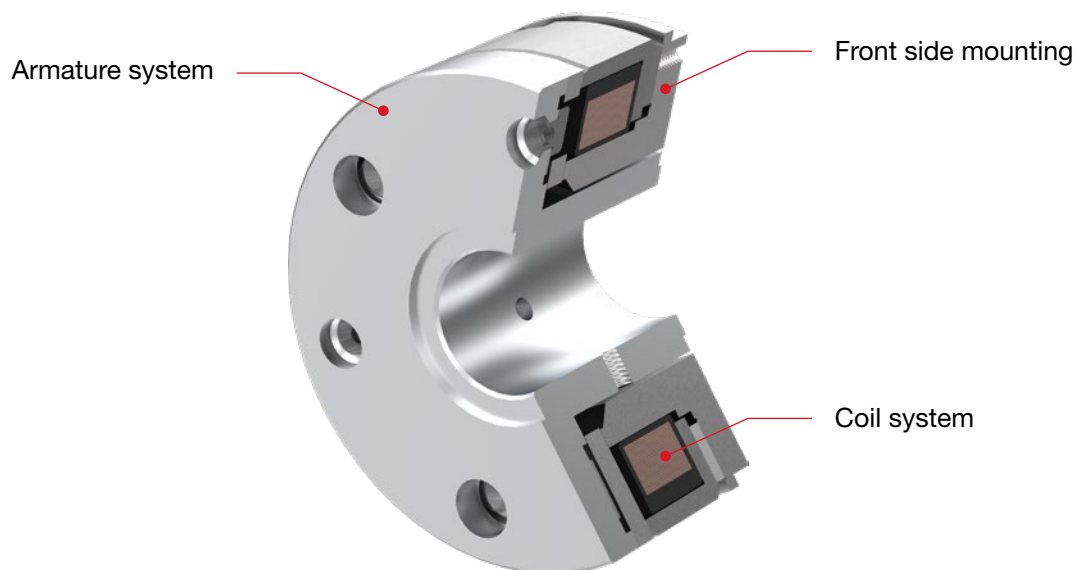

Technical details

Model types	86 611..H00 ; 86 621..H00
Operation mode	Holding brake with emergency stop function
Standard nominal voltage	24 VDC (other variants on request)
Protection class	IP00
Thermal class	F (155°C) ⁵⁾
Torque range	0.01 Nm to 240 Nm
Duty cycle	100% ED
Nominal backlash	0°
Ambient temperature	-5°C to +120°C
Note	Please observe the general information on data sheets and the corresponding operating instructions. Design is subject to change.

Brake size	Min. transmittable torque ¹⁾	Nominal torque ²⁾	Nominal power	Max. rotation speed ³⁾	Max. emergency stop rotation speed	Max. switching energy per emergency stop (Z=1)	Number of emergency stops	Switching time		Max. inertia armature type 200	Max. inertia armature type 800	Max. weight brake incl. armature type 800
	M _s [Nm]	M _{sN} [Nm]	P _N [W]	n _{max} [min ⁻¹]	n [min ⁻¹]	W _{max} [J]		Z _{ges}	Coupling time ⁴⁾			
								t _{c1} [ms]	t _c [ms]	J [kgcm ²]	J [kgcm ²]	m [kg]
01	0.01	0.02	1.8	20000	6000	0.5	300	–	–	0.0004	0.0006	0.012
03	0.4	0.6	6.2	16000	3000	10	500 (standard) 2.000 (extended ⁶⁾)	13	27	0.01	0.018	0.07
04	2.2	2.6	8.2	12000	3000	200		14	28	0.1	0.12	0.19
06	3.2	4.5	10.8	10000	3000	350		19	29	0.23	0.38	0.3
07	11	14	15.6	10000	3000	400		20	29	0.65	1.06	0.6
09	22	26	17	10000	3000	550		25	50	2.14	3.6	1.1
11	40	50	20.2	10000	3000	850		25	73	5.7	9.5	1.4
14	80	100	27	8000	3000	1450		53	97	20.3	31.8	4.1
16	120	160	35	8000	3000	1550		80	150	37.8	57.5	6
21	240	280	50	4000	3000	2000		95	650	140	190	10.5

¹⁾ Minimum guaranteed static torque over lifetime in the specified ambient temperature range with ground-in brake

²⁾ Expected average static torque over lifetime at room temperature with ground-in brake

³⁾ Without emergency stop

⁴⁾ Measured with parallel varistor (quick shutdown)

⁵⁾ Brake size 01 is specified acc. thermal class B (130°C)

⁶⁾ Extended temperature range or increased number of emergency stops with reduced switching energy available on request

Dimensional drawing

Stator types

Type 611 (front side mounting)

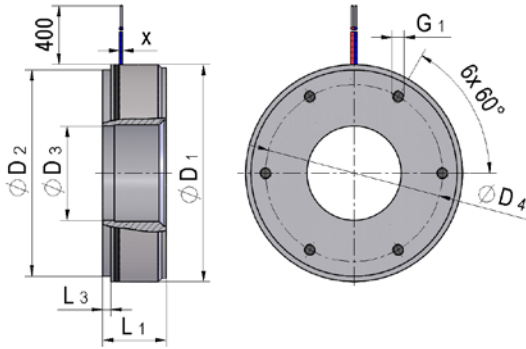

Type 621 (flange side mounting)

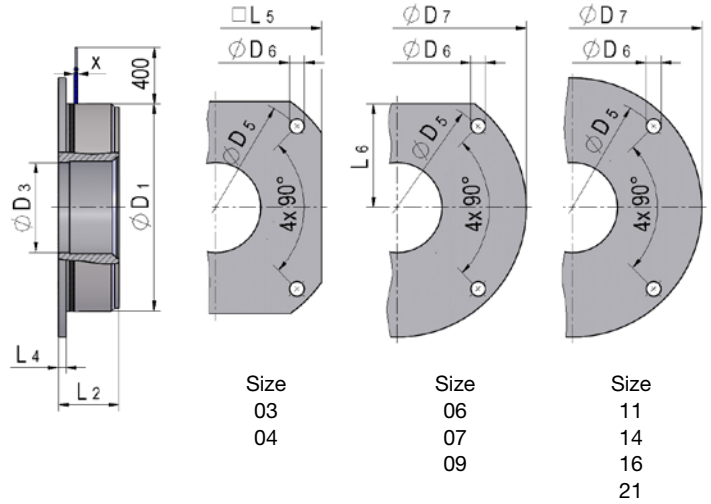

Armature types

Type 200

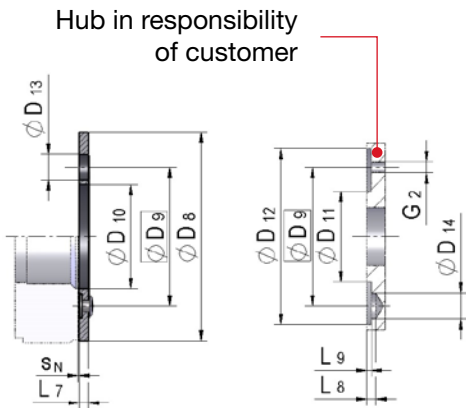

Hub from non-magnetizable material!

Type 300

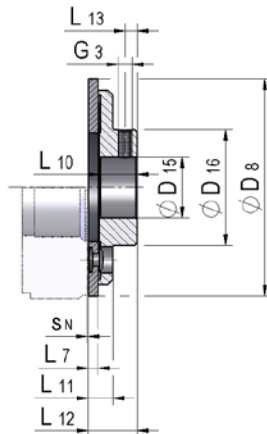

Type 400

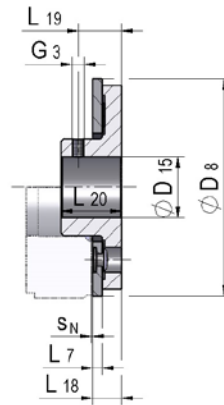

Type 800

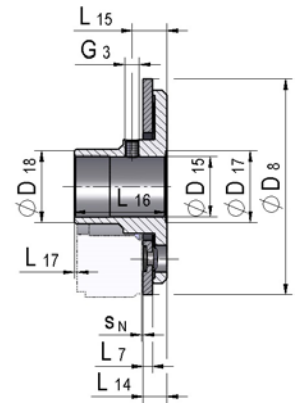

Borehole interface for armature mounting

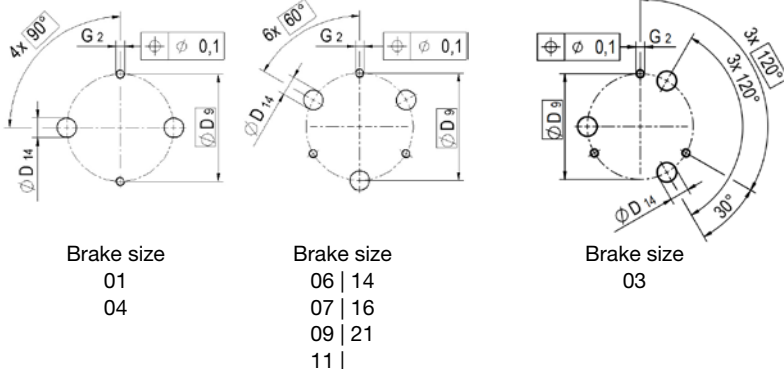

Dimensions

Brake size	Ø D ₁	Ø D ₂	Ø D ₃	Ø D ₄	Ø D ₅	Ø D ₆	Ø D ₇	Ø D ₈	Ø D ₉	Ø D ₁₀	Ø D ₁₁	Ø D ₁₂	Ø D ₁₃	Ø D ₁₄	Ø D ₁₅ ²⁾		Ø D ₁₆	Ø D ₁₇	Ø D ₁₈	G ₁	G ₂	G ₃
	[mm]	[mm]	[mm]	[mm]	[mm]	[mm]	[mm]	[mm]	[mm]	[mm]	[mm]	[mm]	[mm]	[mm]	min.	max.	[mm]	[mm]	[mm]	[mm]	[mm]	[mm]
01	14	14 _{hb}	4.5	8.5	–	–	–	14	9.5	5	5	13	3.5	3.2	1.5 ^{H7}	3 ^{H7}	–	Depending on type of ball bearing ³⁾	Depending on type of ball bearing ³⁾	3xM1.6	2xM1.4	–
03	28	28 _{hb}	9	22	33.5	4x 2.6	–	28.5	19.5	9.3	11	26	5	5	4 ^{H7}	8 ^{H7}	14			6xM2	3xM2	2xM3
04	39.5	40 _{hb}	13	32.5	54	4x 3.5	–	39.5	29	17	16	37	7	7	6 ^{H7}	8 ^{H7}	16			6xM2	2xM3	2xM3 ⁴⁾
06	56	53 _{hb}	24	48	65	4x 4.5	75 _{hb}	56	46	28	35	54	7	7	6 ^{H7}	15 ^{H7}	24			6xM3	3xM3	2xM3
07	70	66.5 _{hb}	30	61	79.5	4x 5.5	90 _{hb}	70	60	37	46	68	8.5	8.5	10 ^{H7}	22 ^{H7}	30			6xM3	3xM4	2xM4
09	90	85.5 _{hb}	40	75	102	4x 6.5	115 _{hb}	90	76	46	60	88	10.5	10.5	10 ^{H7}	30 ^{H7}	40			6xM3	3xM5	2xM5
11	110	104 _{hb}	50	90	121	4x 6.5	132 _{hb}	110	95	59	78	108	12	12	15 ^{H7}	35 ^{H7}	50			6xM4	3xM6	2xM6
14	140	134 _{hb}	70	120	151	4x 6.5	162 _{hb}	140	120	75	98	136	16	16	20 ^{H7}	48 ^{H7}	70			6xM5	3xM8	2xM8
16	160	160 _{hb}	80	120	175	4x 8.4	190 _{hb}	160	135	83	113	156	16	16	20 ^{H7}	62 ^{H7}	79			6xM5	3xM8	2xM8
21	200	200 _{hb}	103	167	215	4x 8.4	230 _{hb}	202	158	114	134	186	18	17	–	–	–			6xM8	3xM10	–

Brake size	L ₁	L ₂	L ₃	L ₄	L ₅	L ₆	L ₇	L ₈	L ₉	L ₁₀	L ₁₁	L ₁₂	L ₁₃	L ₁₄	L ₁₅	L ₁₆	L ₁₇	L ₁₈	L ₁₉	L ₂₀	X	S _N ¹⁾
	[mm]	[mm]	[mm]	[mm]	[mm]	[mm]	[mm]	[mm]	[mm]	[mm]	[mm]	[mm]	[mm]	[mm]	[mm]	[mm]	[mm]	[mm]	[mm]	[mm]	[mm]	[mm ²]
01	14	–	2	–	–	–	1.5	2.2	0.2 ^{+0.05}	–	–	–	–	–	–	–	Depending on type of ball bearing ³⁾	3.7	–	7	0.125	0.09 ^{+0.01}
03	16	16	3.3	1.5	30	–	2	2.2	0.6 ^{+0.05}	8.5	5	10.5	3.5	–	–	–		–	–	–	0.25	0.15 ^{+0.06}
04	21	23	4.9	2	45	–	4.9	2.2	1.5 ^{+0.05}	15	8.4	17.5	6	–	–	–		8.4	–	15	0.25	0.2 ^{+0.1}
06	20.8	20.8	3	3.1	–	28	3	2.8	1.0 ^{+0.05}	17	8	20	6	8.5	15	29		8	11	17	0.25	0.2 ^{+0.1}
07	25.3	25.3	3.5	3.5	–	35	3.5	3	1.2 ^{+0.05}	20	9.5	23.5	7	10	13	35		9.5	13	20	0.25	0.3 ^{+0.1}
09	26.7	26.7	3.5	3.5	–	45	4	4	1.3 ^{+0.05}	25	12	29	7	10.6	20	37		12	18	25	0.25	0.3 ^{+0.1}
11	30.7	30.7	5	5	–	–	5	5	1.6 ^{+0.05}	30	14	35	11	13	22.5	43.5		14	19	30	0.62	0.3 ^{+0.1}
14	37.2	37.2	6.5	6.5	–	–	6.5	6	2.3 ^{+0.05}	40	16	46.5	15	16.5	29.5	53.5		16	25	40	0.96	0.3 ^{+0.1}
16	43.2	43.2	12	7	–	–	7	6	2.8 ^{+0.05}	40	16.5	47	15	–	–	–		16.5	25	40	0.62	0.3 ^{+0.1}
21	53.5	53.5	13	5	–	–	12.3	6	4.2 ^{+0.1}	–	–	–	–	–	–	–		–	–	–	0.96	0.4 ^{+0.1}

¹⁾ Nominal air gap

²⁾ Keyway on request (acc. DIN 6885-1)

³⁾ Specification need to be agreed

⁴⁾ Type 400 without thread

Why is Kendrion the **perfect** partner?

The customer is in the focus of our activities. The complete Kendrion team is committed to meet the requirements and wishes of our global customers. We place great value on partnership and open communication.

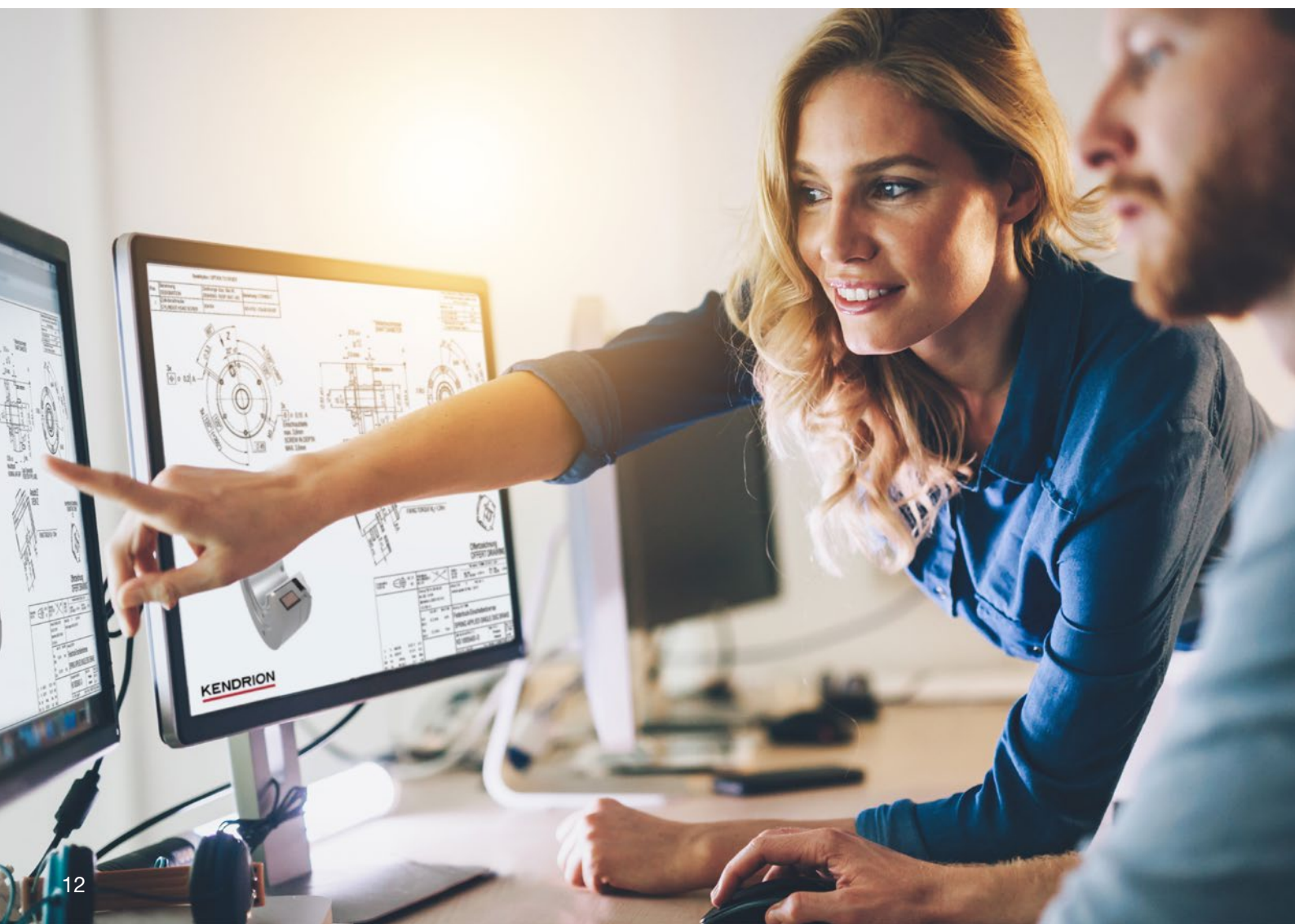

“We are a **full-line provider** and specialist for **permanent magnet** and **spring-applied brakes** for technologically demanding servomotors.”

- Our product series convince by great variability and the highest performance density.
- With our products we offer suitable brake solutions for each application in the technologically demanding industries of the future.



“**Customized to your application**, the design of our brakes is the best possible combination of technology and economy.”

- A comprehensive standard product line, combined with extensive technological know-how enables us to develop customized solutions fast and with great flexibility.
- Open and quick communication between customer, sales, and technology supports a focused project management.

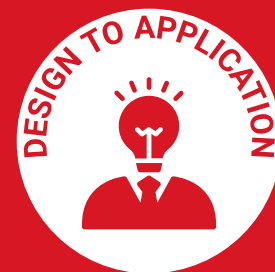

“Our products are used in fast growing markets of the future such as robotics, **AGVs, wind power** and **medical technology.**”

- We consistently focus on market development, are looking for innovative technology trends and new industries for holding applications.
- Based on many years of cooperation with leading companies, we have built up a strong and extensive market know-how.



“We offer highest safety standards through our **unique validation and quality processes.**”

- For ultimate customer satisfaction, we guarantee product-specific data over the entire lifetime of the brake.
- Our certifications and globally coordinated processes guarantee the highest quality standards worldwide.



Order Key

Our order key helps you to assemble the brake variant. It consists of stator type, brake size and version.

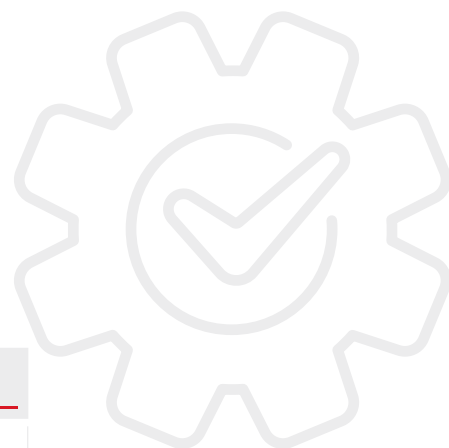

	86	6	-	1	-	-	H	-	-
Stator type			1						
			2						
Brake size						01			
						03			
						04			
						06			
						07			
						09			
						11			
						14			
						16			
						21			
Version								00	
								XY	
Example	86	6	2	1	0	7	H	0	0

PM Line with stator mounted on flange side, size 07, standard series

Customized solutions – tailored exactly to your needs

Automation solutions have become an indispensable part of industry and everyday life. In this context, it is often the brakes that ensure safety: They hold loads and brake reliably in an emergency.

Just as automation continues to evolve, brakes must also face higher demands - forward-looking products are in demand. At the same time, quality and safety must be unconditionally guaranteed. This is a challenge that Kendrion Industrial Brakes meets with passion and care.



When it comes to developing customer-specific solutions, we have three aces up our sleeves:

- With our **new agile organization**, we respond much faster to customer requests.
- Our **modularly developed products** enable new configurations without complete redevelopment.
- The **global structure of our organization** bundles competencies and ensures valuable knowledge transfer.

This makes us a competent and reliable partner for our customers – starting with industry-savvy consulting, through product development with practical experience, to uncompromising quality assurance.



We will find the
solution that suits
you best!

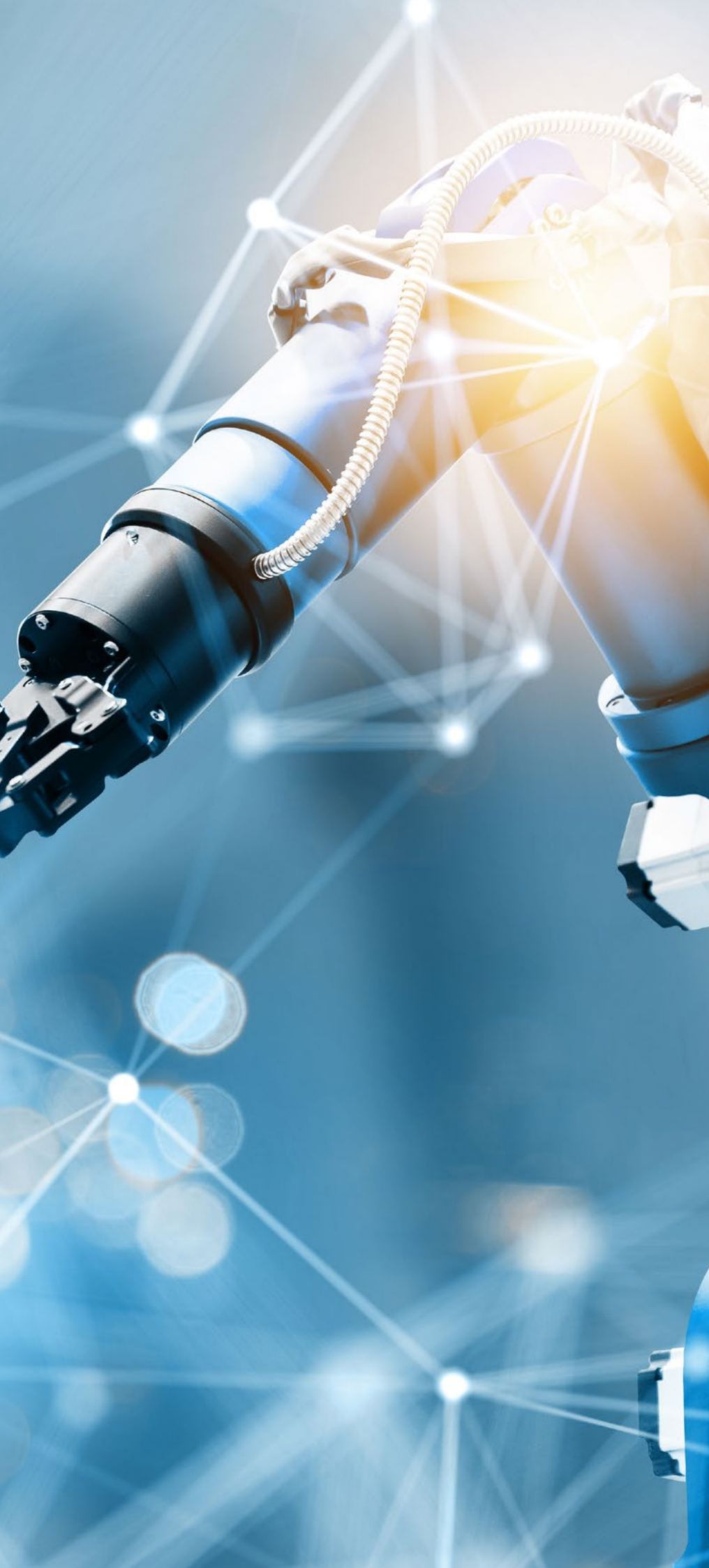

KENDRION

Kendrion (Villingen) GmbH

Wilhelm-Binder-Strasse 4-6
78048 Villingen-Schwenningen
Germany

T +49 7721 877-1417
sales-villingen-ib@kendrion.com

www.kendrion.com

© KENDRION 26.07.2024

PRECISION. SAFETY. MOTION.